

OPEN FACE BOOTH



SILVER EDITION BOOTHS are for the economy minded buyer. Prices do not include installation or permits

Visit our website www.skbowling.com for our complete product line. We also manufacture the [Paint Per-](#)

SPECIFICATIONS

- 18 gauge galvanized steel construction
- 48" 4 tube fluorescent light fixtures with clear tempered glass
- (Tubeaxial fan with 2 hp 3 phase motor, belts pulleys and sheave
- Exhaust filters/filter grids - 20" x 20"
- Manometer
- All hardware, fasteners, sealants
- Assembly Instructions
- UL Listed Components
- Assembles in 1-3 days

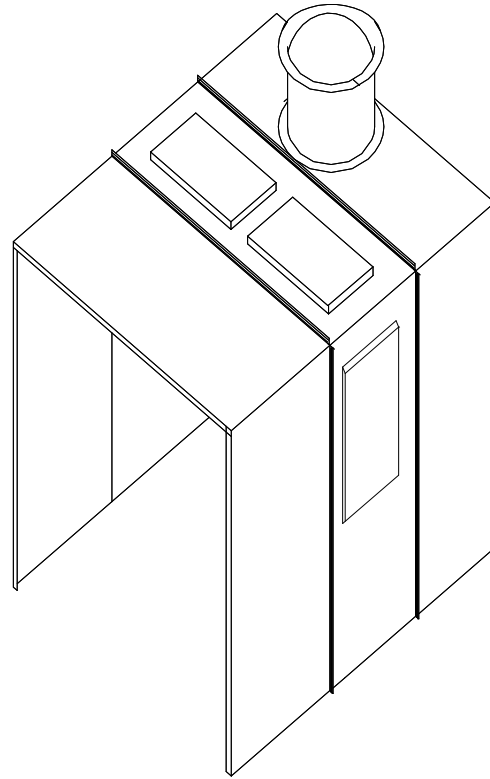

MODELS AVAILABLE *

add freight and crating to all

	Inside Dimensions
S/E OF 0806-7	8'w x 6'5" d x 7' h
S/E OF 1006-7	10'w x 6'5" d x 7' h
S/E OF 1208-7	12'w x 8' d x 7' h
S/E OF 1408-7	14'w x 7'8" d x 7' h
S/E OF 1606-7	16'w x 7'8" d x 7' h

Model S/E OF 0806-7

shown with 2 extra side light fixtures

All UL and ETL listed components are used. Assembly Instructions are included. Permit packages are available.

Optional Features

- Exhaust Package*
- ** Single Phase motor*
- Side Light Fixtures (each)*
- Crate for booth*
- Freight to*

Installation and Permits are the responsibility of the purchaser. Booths are manufactured to NFPA33, OSHA, NEC and BOCA guidelines, but nothing is implied or expressed that precludes them from being installed to all state and local building codes.

Silver Edition Booths Distributed By:



Manufactured and Installed by: **S.K BOWLING COMPANY** 4475 Technology Dr. Wilson, NC 27896
252-243-2383 phone 252-237-5289 fax



www.skbowling.com
email: info@skbowling.com